

The background of the entire page is a blue-tinted molecular structure. It features a network of dark blue and white spheres connected by thin, light blue lines, representing chemical bonds. The spheres vary in size and are arranged in a complex, interconnected pattern, creating a sense of depth and scientific precision.

ENSURING YOUR SAFETY

- 003** LABOR SECURITY SYSTEM SRL
- 005** WHY CHOOSING OUR PRODUCTS
- 007** SAFETYBOX® FLAMMABLES
- 017** SAFETYBOX® CHEMICALS ACIDS BASES
- 029** SAFETYBOX® KEMFIRE®
- 039** SAFETYBOX® COMPRESSED GAS
- 047** CARBOX®
- 059** UTILITIES
- 071** NOTES



LABOR SECURITY SYSTEM

Labor Security System is a leading company in the planning and production of safety cabinets **SAFETYBOX®** for the storage of flammable products, compressed gas cylinders, acids and bases, as well as charcoal filters **CARBOX®**. Pioneering, innovation and constant attention to customer's needs are the features that distinguish the company for over 20 years.



MISSION

To guarantee the highest standards of quality with a reliable, functional and CERTIFIED product, as well as technologically competitive, in compliance with the strictest European safety standards.

CERTIFICATIONS

Since 1995 the company has been **certified UNI EN ISO 9001** by TÜV SÜD-Italy, internationally known, especially for the rigidity of regulations, to which both the company organization and the product realization should comply.

SAFETYBOX® products are certified by **TÜV Production monitored and Safety tested**, which guarantees both the quality of the product and the control of the productive process: from the used materials to the final testing.

The cabinets are **CERTIFIED according to EUROPEAN STANDARDS EN 14470-1, EN 14470-2, EN 14727 and EN 61010-1**. Fire tests of all cabinets of the lines for **flammable and compressed gas cylinders** are carried out at accredited institutions.



CUSTOMER FOCUS AND RESEARCH

Innovation, research and tradition reliability are recurring themes, consolidated over 25 years of activity.

The utmost attention to the customer is manifested in the study and production of products always in line with the needs of the customer, in compliance with current safety regulations, providing a pre- and post-sales assistance always up-to-date, competent, precise and prompt.

The Company provides the proper training and information to resellers through in-depth courses that take place at Labor Security System showroom. Currently present with its dealers across the country and in continuous expansion in the international market, the Company has a **large warehouse** in which over 400 different cabinets are stored, ready to be shipped to the customer within **24 hours** from receipt of order.

WHY CHOOSING OUR PRODUCTS



MADE IN ITALY

Made in Italy has always been synonymous with excellence, symbol and value of products that are characterized by durability and attention to details. We carefully check all purchasing processes, testing the quality of each individual component, to maintain the highest quality standards. Our safety cabinets are entirely produced in Italy.

PROMPT DELIVERY

Thanks to the huge availability of products in stock, every model is ready to be shipped within 24 hours from receipt of order.

ASSISTANCE

Prompt and competent pre- and post-sale assistance provided by LSS is a further demonstration of the utmost attention to the customer. Your satisfaction is our priority.

PRODUCT INSURANCE

All cabinets have "Product and Public Liability Insurance" which covers any damage to persons and objects caused by manufacturing defects. The insurance is valid for all lifelong of the cabinet.

TESTING AND TRACKING

Each cabinet is tested in a 1:1 scale; later on a serial number for product traceability is assigned to each cabinet.

ENVIRONMENTAL CARE

Labor Security System offers cutting edge solutions with an eye to sustainable development. Through the use of eco-friendly materials, we are able to offer products that combine maximum effectiveness with energy saving, thereby ensuring the safety of both workers and the environment.

NOT AN ORDINARY MECHANISM

A unique mechanism allows the easiness of cabinets' opening. Designed with door locking device at 50 ° C in compliance with the highest safety standards.

CERTIFIED STORAGE OF CHEMICAL PRODUCTS

LSS is the only company that can provide the product certificate, issued by the accredited institute TÜV SÜD, for the cabinets destined to the storage of CHEMICALS PRODUCTS.

PALLETIZED BASE

Easy handling thanks to the **CERTIFIED** palletized base.

LOCK

All safety cabinets SAFETYBOX® come with a smart locking system that simplifies the replacement of the lock in case of loss and / or breakage of the key.

Also available with digital coding system TOUCH CODE.



SAFETYBOX®
STORAGE OF
FLAMMABLE
SUBSTANCES

Sodium hydroxyde 0.25 mol/l (N/4)
 Sodio hidróxido 0.25 mol/l (N/4)
 Natronlauge 0.25 mol/l (N)
 JN 1824
 Batch Number 1B719071C
 Expiry Date 2013/02

Safety cabinets for the storage of liquid and solid flammable products in compliance with **EN 14470-1, EN 14727.**

INDEX

FLAMMABLES SMART 09
 FLAMMABLES CM 11
 FLAMMABLES UNDERBENCH..... 13
 ACCESSORIES..... 15

AC 1200 S
AC 900 S
AC 600 S

The most elegant, innovative and lighter safety cabinet on the market.
 "TYPE 90" fire resistance – 90 minutes TÜV Certified.



AC 1200 S



AC 600 S



- Completely produced in pickled steel, 10/10 mm thickness, painted with epoxide acid-proof dusts and passage through thermic tunnel at 200°C. Thickness of painting from a minimum of 60µm (micron) to a maximum of 250µm (micron) as per UNI EN ISO 9001 procedure.
- **Certified palletized base:** for easier transportation of the cabinet.
- **External monolithic construction, internal body resistant to corrosive products.**
- Innovative fire-proof insulation made of highly fire resistant material, completely ecological.
- **Double, inflatable and anti-dust trimmings, with protection against "cold and hot fumes".**
- Door's closure with **thermic device at 50°C. Not electric.**
- **Patented safety catch "Ignis-lock®"** that keeps the doors closed in case of fire.
- Two mechanical certified safety valves with automatic closure at 70 ± 10°C. (Ø 100 mm).
- **3 tray-shaped shelves adjustable in height by racks, and bottom basin;** all made of electrogalvanized steel painted with epoxide acid-proof dusts.
- Security lock with key and extractable cylinder.
- "Danger" warning stickers (DIN 4844 and ISO 3864).
- Grounding connection to discharge build-up of static electricity.
- Levelling feet for balance.
- **"Product and public liability insurance" valid for all lifelong of the cabinet.**
- Usage and maintenance manual.
- Packaging with "Tipping over system®" device.

• **LIGHTER**
 • **MORE ROOMY**
 • **OPENING WITH NO EXTERNAL HINGES**
 • **INTERNAL IGNIS-LOCK®**

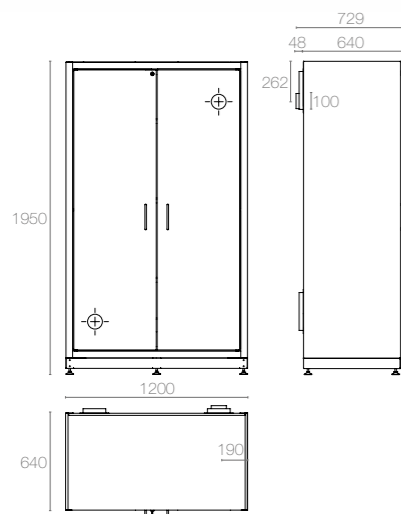

AC 1200 S
 -External dimensions (LxDxH): 1200x640x1950 mm
 -Internal dimensions (LxDxH): 1053x495x1731 mm
 -Weight: 380 Kg
 -Storage capacity: ~902 lt
 -Shelf loading: 80 Kg

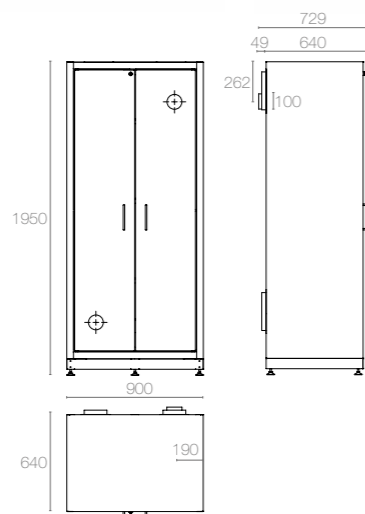

AC 900 S
 -External dimensions (LxDxH): 900x640x1950 mm
 -Internal dimensions (LxDxH): 753x495x1731 mm
 -Weight: 305 Kg
 -Storage capacity: ~645 lt
 -Shelf loading: 80 Kg

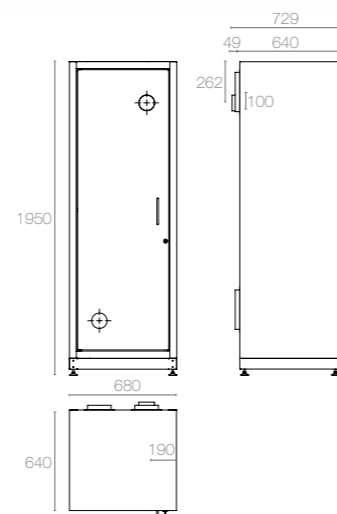

AC 600 S
 -External dimensions (LxDxH): 680x640x1950 mm
 -Internal dimensions (LxDxH): 533x495x1731 mm
 -Weight: 252 Kg
 -Storage capacity: ~456 lt
 -Shelf loading: 80 Kg

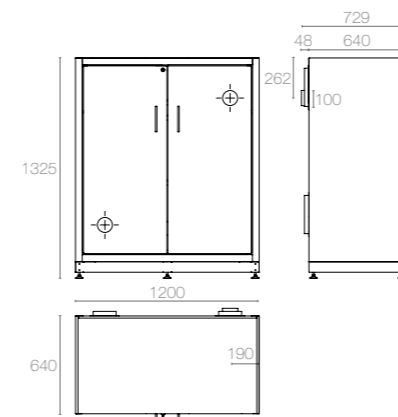

AC 1200/130 S
 -External dimensions (LxDxH): 1200x640x1325 mm
 -Internal dimensions (LxDxH): 1053x495x1110 mm
 -Weight: 275 kg
 -Storage capacity: ~578 lt
 -Shelf loading: 80 Kg

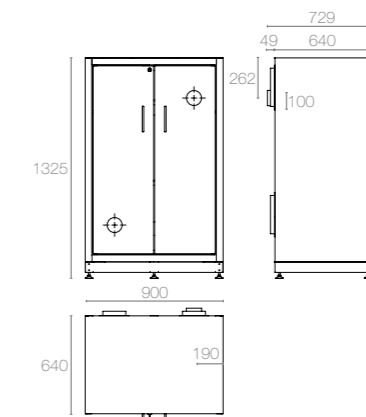

AC 900/130 S
 -External dimensions (LxDxH): 900x640x1325 mm
 -Internal dimensions (LxDxH): 753x495x1110 mm
 -Weight: 218 kg
 -Storage capacity: ~413 lt
 -Shelf loading: 80 Kg

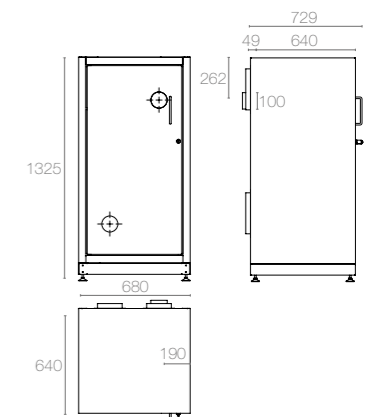

AC 600/130 S
 -External dimensions (LxDxH): 680x640x1325 mm
 -Internal dimensions (LxDxH): 533x495x1110 mm
 -Weight: 187 kg
 -Storage capacity: ~292 lt
 -Shelf loading: 80 Kg

OTHER AVAILABLE MODELS

HEIGHT 1300 MM AVAILABLE ON DEMAND

AVAILABLE WITH SLIDING SHELVES ON DEMAND

AC 1200 CM
AC 600 CM

“TYPE 90” fire resistance – 90 minutes TÜV Certified.



AC 1200 CM



AC 600 CM



- Completely produced in pickled steel, 10/10 mm thickness, painted with epoxide acid-proof dusts and passage through thermic tunnel at 200°C. Thickness of painting from a minimum of 60µm (micron) to a maximum of 250µm (micron) as per UNI EN ISO 9001 procedure.
- **Certified palletized base:** for easier transportation of the cabinet.
- **External monolithic construction, internal body resistant to corrosive products.**
- Fire-proof insulation made of highly fire resistant material, completely ecological.
- **Double, inflatable and anti-dust trimmings, with protection against “cold and hot fumes”.**
- Door's closure with **thermic device at 50°C. Not electric.**
- **Patented safety catch “Ignis-lock®”** that keeps the doors closed in case of fire.
- Two mechanical certified safety valves with automatic closure at 70 ± 10°C. (Ø 100 mm).
- **3 tray-shaped shelves adjustable in height by racks, and bottom basin;** all made of electrogalvanized steel painted with epoxide acid-proof dusts.
- Anti-spark hinges.
- Security lock with key and extractable cylinder.
- “Danger” warning stickers (DIN 4844 and ISO 3864).
- Grounding connection to discharge build-up of static electricity.
- Levelling feet for balance.
- **“Product and public liability insurance” valid for all lifelong of the cabinet.**
- Usage and maintenance manual.
- **Packaging with “Tipping over system®” device.**

ACCESSORIES

Easy Going®. Rolling system to easily move the cabinet for short distances. (standard on AC 1200 CM).

OTHER AVAILABLE MODELS

AC 1200 CM E - AC 600 CM E



- 3 fixed shelves, not on racks, with bottom basin.
- No patented safety catch “Ignis-lock®”.
- Light packing

AC 1200 T30 - AC 600 T30 - MINIBOX



“Type 30” Fire resistance – 30 minutes.

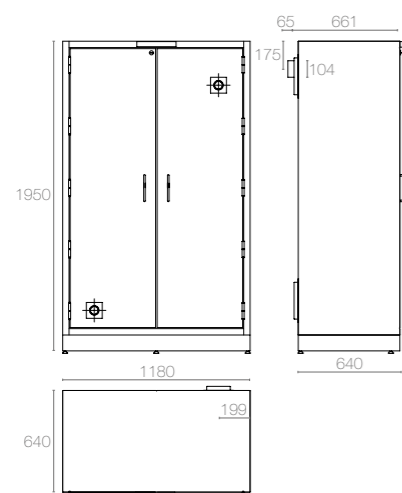

AC 1200 CM
 -External dimensions (LxDxH): 1180x640x1950 mm
 -Internal dimensions (LxDxH): 1015x445x1685 mm
 -Weight: 490 Kg
 -Storage capacity: ~ 761 lt
 -Shelf loading: 80 kg

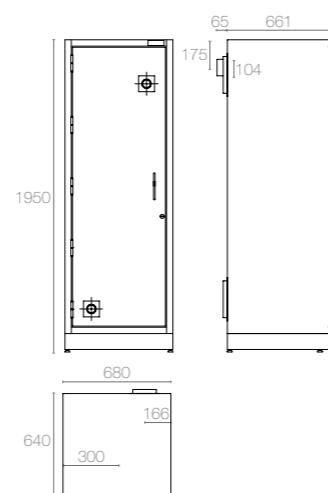

AC 600 CM
 -External dimensions (LxDxH): 680x640x1950 mm
 -Internal dimensions (LxDxH): 515x445x1685 mm
 -Weight: 350 Kg
 -Storage capacity: ~ 386 lt
 -Shelf loading: 80 kg

AC 1200/50 CM
AC 900/50 CM
AC 600/50 CM

“TYPE 90” fire resistance – 90 minutes TÜV Certified.



AC 1200/50 CM



AC 900/50 CM



AC 600/50 CM



KIT05
 Certified device to pour liquids, for underbench cabinets.

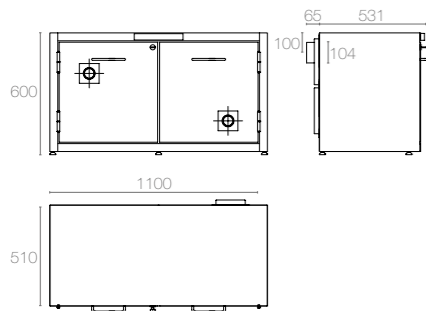

AC 1200/50 CM
 -External dimensions (LxDxH): 1100x510x600 mm
 -Internal dimensions (LxDxH): 935x395x445 mm
 -Weight: 170 Kg
 -Storage capacity: ~164 lt
 -Shelf loading: 80 kg

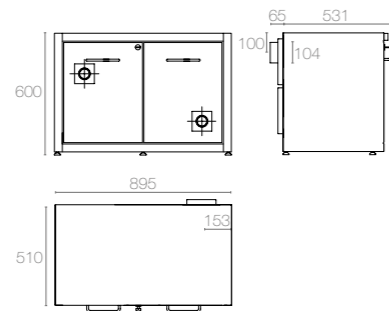

AC 900/50 CM
 -External dimensions (LxDxH): 895x510x600 mm
 -Internal dimensions (LxDxH): 730x395x440 mm
 -Weight: 145 Kg
 -Storage capacity: ~114 lt
 -Shelf loading: 80 kg

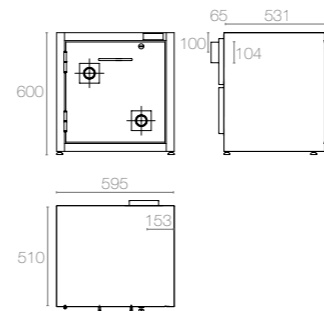

AC 600/50 CM
 -External dimensions (LxDxH): 595x510x600 mm
 -Internal dimensions (LxDxH): 430x395x445 mm
 -Weight: 100 Kg
 -Storage capacity: ~75 lt
 -Shelf loading: 80 kg



- Completely produced in pickled steel, 10/10 mm thickness, painted with epoxide acid-proof dusts and passage through thermic tunnel at 200°C. Thickness of painting from a minimum of 60µm (micron) to a maximum of 250µm (micron) as per UNI EN ISO 9001 procedure.
- **External monolithic construction, internal body resistant to corrosive products.**
- New fire-proof insulation made of highly fire resistant material, completely ecological.
- **Double, inflatable and anti-dust trimmings, with protection against “cold and hot fumes”.**
- Door's closure with **thermic device at 50°C. Not electric.**
- **Patented safety catch “Ignis-lock®”** that keeps the doors closed in case of fire.
- Two mechanical certified safety valves with automatic closure at 70 ± 10°C. (Ø 100 mm).
- **Bottom basin with drilled shelf**, made of electrogalvanized steel painted with epoxide acid-proof dusts.
- Security lock with key and extractable cylinder.
- “Danger” warning stickers (DIN 4844 and ISO 3864).
- Grounding connection to discharge build-up of static electricity.
- Levelling feet for balance.
- **“Product and public liability insurance” valid for all lifelong of the cabinet.**
- Usage and maintenance manual.

OTHER AVAILABLE MODELS: WITH DRAWER

AC 1200/50 CM DD - AC 1200/50 CM D
AC 900/50 CM D - AC 600/50 CM D

- Safety closing system for drawer with thermic device at 50°C. Not electric.
- No patented safety catch “Ignis-lock®”.



AC 1200/50 CM DD



AC 1200/50 CM D



AC 900/50 CM D



AC 600/50 CM D

MINIBOX

- Safety cabinet for the storage of 4 bottles of 2.5 lts. of liquid and solid flammable products.
- Fire resistance “TYPE30” - 30minutes.



Accessories



KIT05
CERTIFIED device
to pour liquids,
for underbench
cabinets.

**UNICUM
ASPIRATOR
AND FILTER**

in a single box
(possibility to
supply it with
thermostat).



**EXHAUST FUMES
CONVEYOR.**

**ANTI-SPARK
OR ATEX
ASPIRATORS**
220V/230V.



**INTERNAL
FILTRATION
SYSTEM**
with activated
charcoal filter and
Cunctator®.



CUBETTO®
Controlled cooling unit for safety
cabinets **Safetybox®** with
recorded memory device.

ECOBIX® PVC

Container for
polluting liquids
with full/empty
signaling device.
Customized
dimensions.



**STAINLESS
STEEL ECOBIX®**

Container for
polluting liquids
with full/empty
signaling
device. Customized
dimensions.



**ADDITIONAL
SHELVES**

made of acid-proof
painted steel or AISI
304 STAINLESS
STEEL.



EASY-GOING®

Roller system for
short moving.

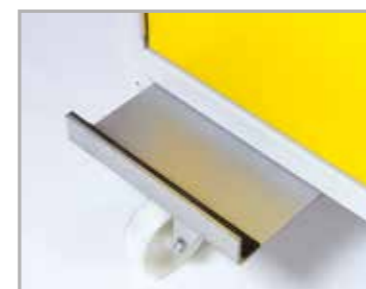

EASY-ROLLER®

Rolling system to be
positioned under the cabinet
for easy handling during
logistics.



TOUCH CODE

Opening doors'
system through
fingerprint detection,
with ability to record
multiple users.



**SAFETYBOX®
STORAGE OF
CHEMICALS
ACIDS
BASES**

Safety cabinets for the storage of chemicals,
acids and bases products.

INDEX

CHEMICALS FORCED VENTILATION.....	19
CHEMICALS NATURAL VENTILATION.....	23
CHEMICALS UNDERBENCH.....	25
ACCESSORIES.....	27

AA 120 NEW
AA 600

Cabinet with aspirator and filter, TÜV and CE certified
In compliance with EN 61010-1, EN 14727, TEST PPP
52125A



AA 120 NEW



AA 600



- Completely produced in pickled and electrogalvanized steel, 10/10 mm thickness, painted with epoxide acid-proof dusts. Thickness of painting from a minimum of 60µm (micron) to a maximum of 250µm (micron) as per UNI EN ISO 9001 procedure.
- **Monolithic construction, resistant to corrosive products.**
- **Certified palletized base:** for easier transportation of the cabinet.
- **3 tray-shaped shelves adjustable in height by racks, with bottom basin,** made of electrogalvanized steel painted with epoxide acid-proof dusts.
- Doors opening up to 110°.
- Acid-proof hidden hinges.
- Security lock with key and extractable cylinder.
- **E-Flow® smart aspiration system** (standard on models AA120NEW, AAW120NEW).
- **Activated charcoal filter Carbox® with electronic device Cunctator®** for charcoal filter replacement.
- **Electroaspirator IMQ IPX4,** in compliance with EN 60335-1, EN 60335-2-80 and EN 50366 norms.
- Input voltage: Volt 220/230.
- Max absorbed power: 65W.
- ON/OFF lamp.
- "Danger" warning stickers.
- Grounding connection to discharge build-up of static electricity.
- Levelling feet for balance.
- **"Product and public liability insurance" valid for all lifelong of the cabinet.**
- Usage and maintenance manual.
- **Packaging with "Tipping over system®" device.**

OTHER AVAILABLE MODELS

AAW 120 NEW - AAW 600

- With window door.

AAF 120 NEW

- With on/off programmed timer.
- Not TÜV certified.



AAW 120 NEW



AAW 600

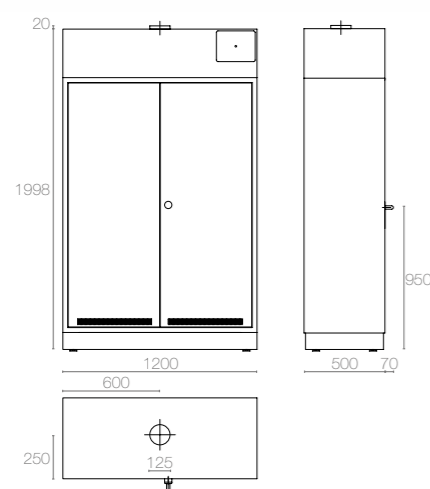

AA 120 NEW
-External dimensions (LxDxH): 1200x500x1998 mm
-Internal dimensions (LxDxH): 1120x450x1500 mm
-Weight: 155 Kg
-Storage capacity: ~766 lt
-Shelf loading: 100 kg

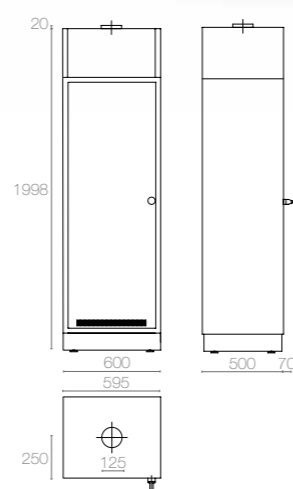

AA 600
-External dimensions (LxDxH): 600x500x1998 mm
-Internal dimensions (LxDxH): 530x450x1500 mm
-Weight: 95 Kg
-Storage capacity: ~357 lt
-Shelf loading: 100 kg

AB 600
AB 1100

Cabinet with aspirator and filter, TÜV and CE certified
In compliance with EN 61010-1, EN 14727, TEST PPP
52125A.



AB 600



AB 1100

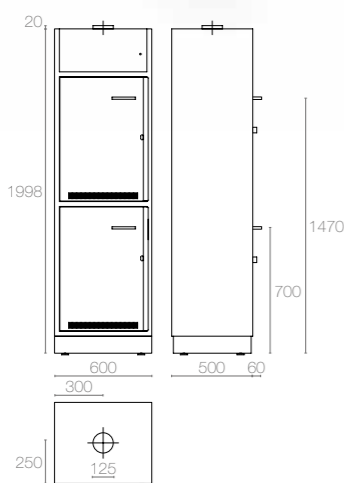

AB 600
-External dimensions (LxDxH): 600x500x1998 mm
-Internal dimensions (LxDxH): 520x440x765+726 mm
-Weight: 100 Kg
-Storage capacity: ~341 lt
-Shelf loading: 100 kg

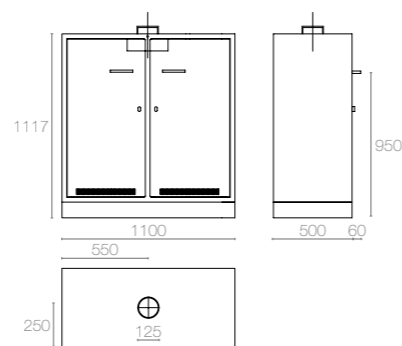

AB 1100
-External dimensions (LxDxH): 1100x500x1117 mm
-Internal dimensions (LxDxH): 490+490x465x1020 mm
-Weight: 75 Kg
-Storage capacity: ~464 lt
-Shelf loading: 100 kg



- Completely produced in pickled and electrogalvanized steel, 10/10 mm thickness, painted with epoxide acid-proof dusts. Thickness of painting from a minimum of 60µm (micron) to a maximum of 250µm (micron) as per UNI EN ISO 9001 procedure.
- **Monolithic construction, resistant to corrosive products.**
- **Certified palletized base:** for easier transportation of the cabinet.
- 2 separate sections, one for acid and one for base products, **tray shaped shelves adjustable in height by racks, and bottom basin.**
- Doors opening up to 110°.
- Acid-proof hidden hinges.
- Security lock with key and extractable cylinder.
- **Activated charcoal filter Carbox® with electronic device Cunctator®** for charcoal filter replacement.
- **Electroaspirator IMQ IPX4**, in compliance with EN 60335-1, EN 60335-2-80 and EN 50366 norms.
- Input voltage: Volt 220/230.
- Max absorbed power: 65W.
- ON/OFF lamp.
- "Danger" warning stickers.
- Grounding connection to discharge build-up of static electricity.
- Levelling feet for balance.
- **"Product and public liability insurance" valid for all lifelong of the cabinet.**
- Usage and maintenance manual.
- **Packaging with "Tipping over system®" device.**

OTHER AVAILABLE MODELS

AB 30/30 EST ON DEMAND

- 2 separate vertical pull-out compartments.
- 4 shelves adjustable in height with tray-shaped container for each section.
- Shelf capacity kg 25.



AB 30/30 EST

A 120 NEW A 600

Cabinet predisposed for connection to a central aspiration system.



A 120 NEW



A 600

- Completely produced in pickled and electrogalvanized steel, 10/10 mm thickness, painted with epoxide acid-proof dusts.
- Thickness of painting from a minimum of 60µm (micron) to a maximum of 250µm (micron) as per UNI EN ISO 9001 procedure.
- Arranged for connection to an external aspiration system.
- **External monolithic construction, internal body resistant to corrosive products.**
- **Certified palletized base:** for easier transportation of the cabinet.
- 3 tray-shaped shelves adjustable in height by racks, with bottom basin, made of electrogalvanized steel painted with epoxide acid-proof dusts.
- Doors opening up to 110°.
- Acid-proof hidden hinges.
- Security lock with key and extractable cylinder.
- "Danger" warning stickers.
- Grounding connection to discharge build-up of static electricity.
- Levelling feet for balance.
- **"Product and public liability insurance" valid for all lifelong of the cabinet.**
- Usage and maintenance manual.
- Packaging with "Tipping over system®" device.

OTHER AVAILABLE MODELS

AW 120 NEW - AW 600

- Window doors.



AW 120 NEW



AW 600

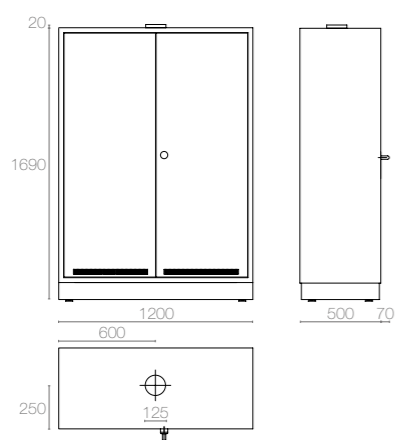

A 120 NEW
 -External dimensions (LxDxH): 1200x500x1690 mm
 -Internal dimensions (LxDxH): 1120x450x1500 mm
 -Weight: 125 Kg
 -Storage capacity: ~766 lt
 -Shelf loading: 100 kg

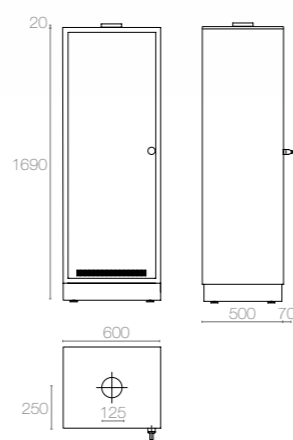

A 600
 -External dimensions (LxDxH): 600x500x1690 mm
 -Internal dimensions (LxDxH): 530x450x1500 mm
 -Weight: 80 Kg
 -Storage capacity: ~357 lt
 -Shelf loading: 100 kg

AB 1200/50
AB 900/50
A 600/50

Underbench cabinet with aspirator and filter, TÜV and CE certified.
 In compliance with EN 61010-1, EN 14727, TEST PPP 52125A.



AB 1200/50



AB 900/50



A 600/50



- Completely produced in pickled and electrogalvanized steel, 10/10 mm thickness, painted with epoxide acid-proof dusts. Thickness of painting from a minimum of 60µm (micron) to a maximum of 250µm (micron) as per UNI EN ISO 9001 procedure.
- **Monolithic construction, resistant to corrosive products.**
- **Certified palletized base:** for easier transportation of the cabinet.
- 2 separate sections, one for acid and one for base products (depending on the model).
- **Watertight bottom basin with drilled shelf.**
- Doors opening up to 110°.
- Acid-proof hidden hinges.
- Security lock with key and extractable cylinder.
- **Electroaspirator IMQ IPX4**, in compliance with EN 60335-1, EN 60335-2-80 and EN 50366 norms.
- **Arranged for activated charcoal filter Carbox® with electronic device Cunctator®** for charcoal filter replacement.
- Input voltage: Volt 220/230.
- Max absorbed power: 65W.
- ON/OFF lamp.
- "Danger" warning stickers.
- Grounding connection to discharge build-up of static electricity.
- Levelling feet for balance.
- **"Product and public liability insurance" valid for all lifelong of the cabinet.**
- Usage and maintenance manual.

OTHER AVAILABLE MODELS

MF1 - MF3

- Board or wall cabinet for the storage of poorly aggressive products.
- Security lock with key.
- 2 removable shelves.
- Not aspirated.
- Not TÜV certified.

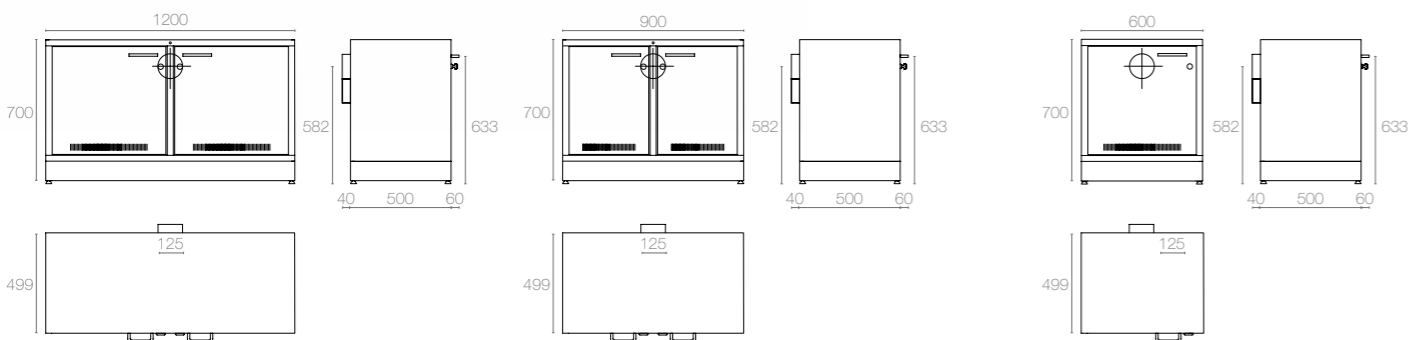

AB 1200/50
 •External dimensions (LxDxH): 1200x500x700 mm
 •Internal dimensions (LxDxH): 530+530x465x555 mm
 •Weight: 70 Kg
 •Storage capacity: ~295 lt
 •Shelf loading: 100 kg

AB 900/50
 •External dimensions (LxDxH): 900x500x700 mm
 •Internal dimensions (LxDxH): 450+450x465x555 mm
 •Weight: 55 Kg
 •Storage capacity: ~224 lt
 •Shelf loading: 100 kg

A 600/50
 •External dimensions (LxDxH): 600x500x700 mm
 •Internal dimensions (LxDxH): 530x465x555 mm
 •Weight: 45 Kg
 •Storage capacity: ~147 lt
 •Shelf loading: 100 kg



BOX VELENI MF1
 •External dimensions (LxDxH): 465x200x500 mm
BOX VELENI MF3
 •External dimensions (LxDxH): 550x350x595 mm

Accessories



E-FLOW® ASPIRATION SYSTEM

for energy saving and maximum safety of the operator.



ANTIMICROBIAL PAINT

to prevent any bacteria proliferation on the treated surfaces, through release of silver ions.



ACTIVATED CHARCOAL FILTER

on demand treated for formaldehyde and other substances.



KIT01

Aspirator and filter for chemicals, acids, bases storage cabinets.



PROPYLENE BASIN

Possibility to supply the shelves with PP basin.



ADDITIONAL SHELVES

made of acid-proof painted steel or AISI 304 STAINLESS STEEL.



PARTITION WALL KIT

for 120 series, with shelves and racks included.



ECOBIX® PVC

Container for polluting liquids with full/empty signaling device. Customized dimensions.



STAINLESS STEEL ECOBIX®

Container for polluting liquids with full/empty signaling device. Customized dimensions.



TOUCH CODE

Opening doors' system through fingerprint detection, with ability to record multiple users.





SAFETYBOX®
KEMFIRE®

Safety cabinets for the combined storage of chemicals acids and bases and flammable products.

INDEX

KEMFIRE® TALL 31

KEMFIRE® UNDERBENCH 33

ACCESSORIES 37

0.25

0,25 mol/l (N/4)

kyde 0.25 mol/l

0.25 mol/l (N/4)

25 mol/l (N

1B719071C

2013/02

! (Warning symbol)

! (Warning symbol)

! (Warning symbol)

KEMFIRE® 1100 A KEMFIRE® 600 A

Cabinet in compliance with EN 14727, EN 61010-1, EN 14470-1 and PPP 52125A.
"TYPE 90" fire resistance - 90 minutes.
TÜV and CE certified.



KEMFIRE® 1100 A



KEMFIRE® 600 A



- Completely produced in pickled steel, 10/10 mm thickness, painted with epoxide acid-proof dusts and passage through thermic tunnel at 200°C. Thickness of painting from a minimum of 60µm (micron) to a maximum of 250µm (micron) as per UNI EN ISO 9001 procedure.
- **External monolithic construction, internal body resistant to corrosive products.**
- Security lock with key and extractable cylinder.
- "Danger" warning stickers (DIN 4844 and ISO 3864).
- Grounding connection to discharge build-up of static electricity.
- Levelling feet for balance.
- **"Product and public liability insurance" valid for all lifelong of the cabinet.**
- Usage and maintenance manual.
- Packaging with "Tipping over system®" device.

COMPARTMENT FOR CHEMICALS ACIDS BASES PRODUCTS

- Tray-shaped shelves adjustable in height by racks, with bottom basin, made of electrogalvanized steel painted with epoxide acid-proof dusts.
- Activated charcoal filter Carbox® with electronic device Cunctator® for charcoal filter replacement.
- Electroaspirator IMQ IPX4, in compliance with EN 60335-1, EN 60335-2-80 and EN 50366 norms with ON/OFF lamp.
- Input voltage: Volt 220/230.
- Max absorbed power: 65W.

COMPARTMENT FOR FLAMMABLES PRODUCTS

- Fire-proof insulation made of highly fire resistant material, completely ecological.
- Double, inflatable and anti-dust trimmings, and with protection against "cold and hot fumes".
- Door's closure with thermic device at 50°C. Not electric.
- Patented safety catch "Ignis-lock®" that keeps the doors closed in case of fire.
- Two mechanical certified safety valves with automatic closure at 70 ± 10°C. (Ø 100 mm).
- Bottom basin with drilled shelf, made of electrogalvanized steel painted with epoxide acid-proof dusts.

OTHER AVAILABLE MODELS FOR FLAMMABLES COMPARTMENT

- Possibility to supply the cabinet with extractable drawer.

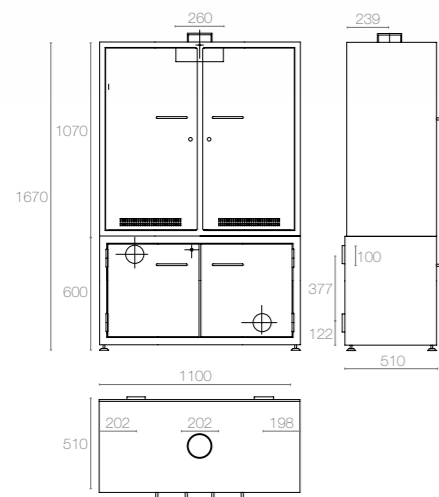

KEMFIRE® 1100 A
 -External dimensions (LxDxH): 1100x510x1670 mm
 -Internal dimensions compartment for chemicals (LxDxH): 490x490x465x1020 mm
 -Internal dimensions compartment for flammables (LxDxH): 935x395x445 mm
 -Weight: 300 Kg
 -Storage capacity: ~465+164 lt
 -Shelf loading: 80/100 kg

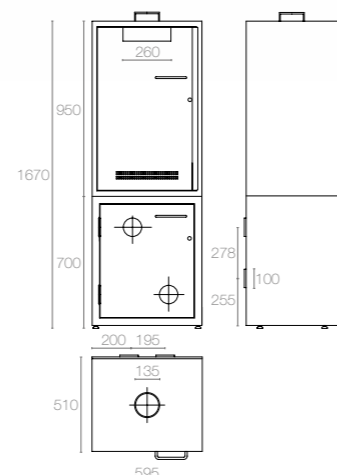

KEMFIRE® 600 A
 -External dimensions (LxDxH): 595x510x1670 mm
 -Internal dimensions compartment for chemicals (LxDxH): 510x474x924 mm
 -Internal dimensions compartment for flammables (LxDxH): 430x395x537 mm
 -Weight: 185 Kg
 -Storage capacity: ~220+75 lt
 -Shelf loading: 80/100 kg

KEMFIRE® 1000/50 TYPE A KEMFIRE® 1200/50 TYPE A

Cabinet in compliance with EN 14727, EN 61010-1, EN 14470-1 and PPP 52125A.
"TYPE 90" fire resistance - 90 minutes.
TÜV and CE certified.



KEMFIRE®
1000/50 TYPE A



KEMFIRE®
1200/50 TYPE A



- Completely produced in pickled steel, 10/10 mm thickness, painted with epoxide acid-proof dusts and passage through thermic tunnel at 200°C. Thickness of painting from a minimum of 60µm (micron) to a maximum of 250µm (micron) as per UNI EN ISO 9001 procedure.
- **External monolithic construction, internal body resistant to corrosive products.**
- Security lock with key and extractable cylinder.
- "Danger" warning stickers (DIN 4844 and ISO 3864).
- Grounding connection to discharge build-up of static electricity.
- Levelling feet for balance.
- **"Product and public liability insurance" valid for all lifelong of the cabinet.**
- Usage and maintenance manual.

COMPARTMENT FOR CHEMICALS ACIDS BASES PRODUCTS

- **Bottom basin with drilled shelf**, made of electrogalvanized steel painted with epoxide acid-proof dusts.
- **Predisposed for activated charcoal filter in grains CARBOX®**
- **Electroaspirator IMQ IPX4**, in compliance with EN 60335-1, EN 60335-2-80 and EN 50366 norms with ON/OFF lamp.
- Input voltage: Volt 220/230.
- Max absorbed power: 65W.

COMPARTMENT FOR FLAMMABLES PRODUCTS

- Fire-proof insulation made of highly fire resistant material, completely ecological.
- **Double, inflatable and anti-dust trimmings, and with protection against "cold and hot fumes".**
- Door's closure with **thermic device at 50°C. Not electric.**
- **Patented safety catch "Ignis-lock®"** that keeps the doors closed in case of fire.
- Two mechanical certified safety valves with automatic closure at 70 ± 10°C. (Ø 100 mm).
- **Bottom basin** with drilled shelf, made of electrogalvanized steel painted with epoxide acid-proof dusts.

OTHER AVAILABLE MODELS FOR FLAMMABLES COMPARTMENT

- Possibility to supply the cabinet with extractable drawer.

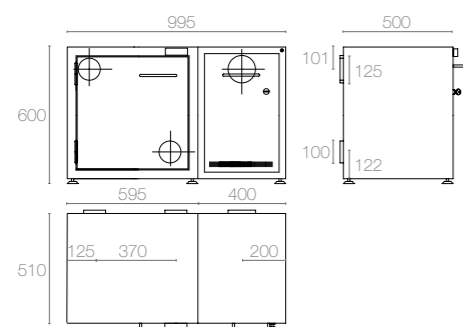

KEMFIRE® 1000/50 TYPE A

- External dimensions (LxDxH): 995x510x600 mm
- Internal dimensions compartment for chemicals (LxDxH): 320 x 460 x 560 mm
- Internal dimensions compartment for flammables (LxDxH): 430x395x445 mm
- Weight: 140 Kg
- Storage capacity: ~85+75 lt
- Shelf loading: 80/100 kg

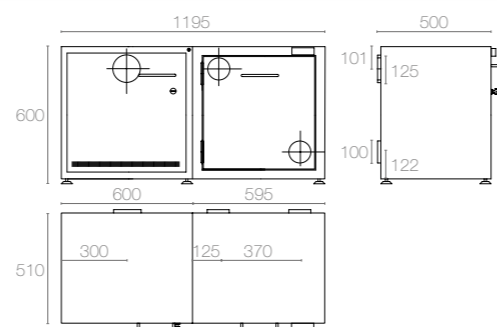

KEMFIRE® 1200/50 TYPE A

- External dimensions (LxDxH): 1195x510x600 mm
- Internal dimensions compartment for chemicals (LxDxH): 510x470x551 mm
- Internal dimensions compartment for flammables (LxDxH): 430x395x445 mm
- Weight: 145 Kg
- Storage capacity: ~132+75 lt
- Shelf loading: 80/100 kg

KEMFIRE® 1500/50 TYPE C KEMFIRE® 1700/50 TYPE A

Cabinet in compliance with EN 14727, EN 61010-1, EN 14470-1 and PPP 52125A.
"TYPE 90" fire resistance - 90 minutes.
TÜV and CE certified.



KEMFIRE® 1500/50 TYPE C



- Completely produced in pickled steel, 10/10 mm thickness, painted with epoxide acid-proof dusts and passage through thermic tunnel at 200°C. Thickness of painting from a minimum of 60µm (micron) to a maximum of 250µm (micron) as per UNI EN ISO 9001 procedure.
- **External monolithic construction, internal body resistant to corrosive products.**
- Security lock with key and extractable cylinder.
- "Danger" warning stickers (DIN 4844 and ISO 3864).
- Grounding connection to discharge build-up of static electricity.
- Levelling feet for balance.
- **"Product and public liability insurance" valid for all lifelong of the cabinet.**
- Usage and maintenance manual.

COMPARTMENT FOR CHEMICALS ACIDS BASES PRODUCTS

- **Bottom basin with drilled shelf**, made of electrogalvanized steel painted with epoxide acid-proof dusts.
- **Predisposed for activated charcoal filter in grains CARBOX®**
- **Electroaspirator IMQ IPX4**, in compliance with EN 60335-1, EN 60335-2-80 and EN 50366 norms with ON/OFF lamp.
- Input voltage: Volt 220/230.
- Max absorbed power: 65W.

COMPARTMENT FOR FLAMMABLES PRODUCTS

- Fire-proof insulation made of highly fire resistant material, completely ecological.
- **Double, inflatable and anti-dust trimmings, and with protection against "cold and hot fumes"**.
- Door's closure with **thermic device at 50°C. Not electric.**
- **Patented safety catch "Ignis-lock®"** that keeps the doors closed in case of fire.
- Two mechanical certified safety valves with automatic closure at 70 ± 10°C. (Ø 100 mm).
- **Bottom basin** with drilled shelf, made of electrogalvanized steel painted with epoxide acid-proof dusts.

OTHER AVAILABLE MODELS FOR FLAMMABLES COMPARTMENT

- Possibility to supply the cabinet with extractable drawer.



KEMFIRE® 1700/50 TYPE A

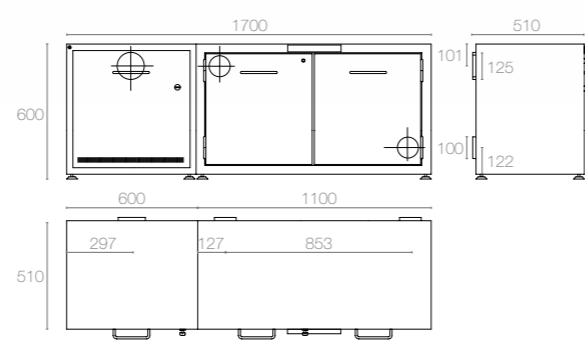
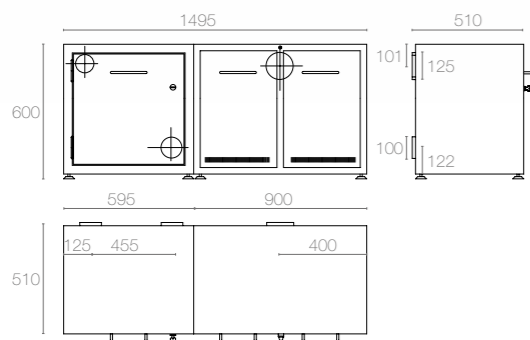

KEMFIRE® 1500/50 TYPE C
 -External dimensions (LxDxH): 1495x510x600 mm
 -Internal dimensions compartment for chemicals (LxDxH): 450x450x465x555 mm
 -Internal dimensions compartment for flammables (LxDxH): 430x395x537 mm
 -Weight: 210 Kg
 -Storage capacity: ~224+75 lt
 -Shelf loading: 80/100 kg

KEMFIRE® 1700/50 TYPE A
 -External dimensions (LxDxH): 1700x510x600 mm
 -Internal dimensions compartment for chemicals (LxDxH): 530x465x555 mm
 -Internal dimensions compartment for flammables (LxDxH): 935x395x445 mm
 -Weight: 265 Kg
 -Storage capacity: ~147+164 lt
 -Shelf loading: 80/100 kg



KIT05
CERTIFIED device
to pour liquids
for underbench
cabinets.



**EXHAUST FUMES
CONVEYOR**



**ANTI-SPARK
OR ATEX
ASPIRATORS**
220V/230V.



**INTERNAL
FILTRATION
SYSTEM**
with activated
charcoal filter and
Cunctator®.



CUBETTO®
Controlled cooling unit for safety
cabinets **Safetybox®** with
recorded memory device.

ECOBIX® PVC
Container for
polluting liquids
with full/empty
signaling device.
Customized
dimensions.



**STAINLESS
STEEL ECOBOX®**
Container for
polluting liquids with
full/empty signaling
device. Customized
dimensions.



**ANTIMICROBIAL
PAINT**
to prevent any
bacteria proliferation
on the treated
surfaces, through
release of silver
ions.

**ADDITIONAL
SHELVES**
made of acid-proof
painted steel or AISI
304 STAINLESS
STEEL.



**PROPYLENE
BASIN**
Possibility to supply
the shelves with PP
basin.

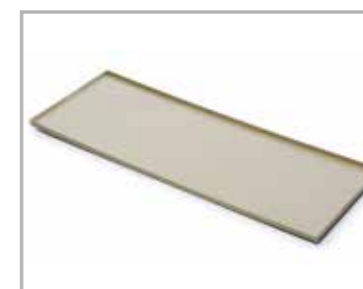

**ACTIVATED
CHARCOAL
FILTER**
on demand
treated for
formaldehyde
and other
substances.



KIT01
Aspirator and filter
for chemicals,
acids, bases
storage cabinets.



TOUCH CODE
Opening doors'
system through
fingerprint detection,
with ability to record
multiple users.

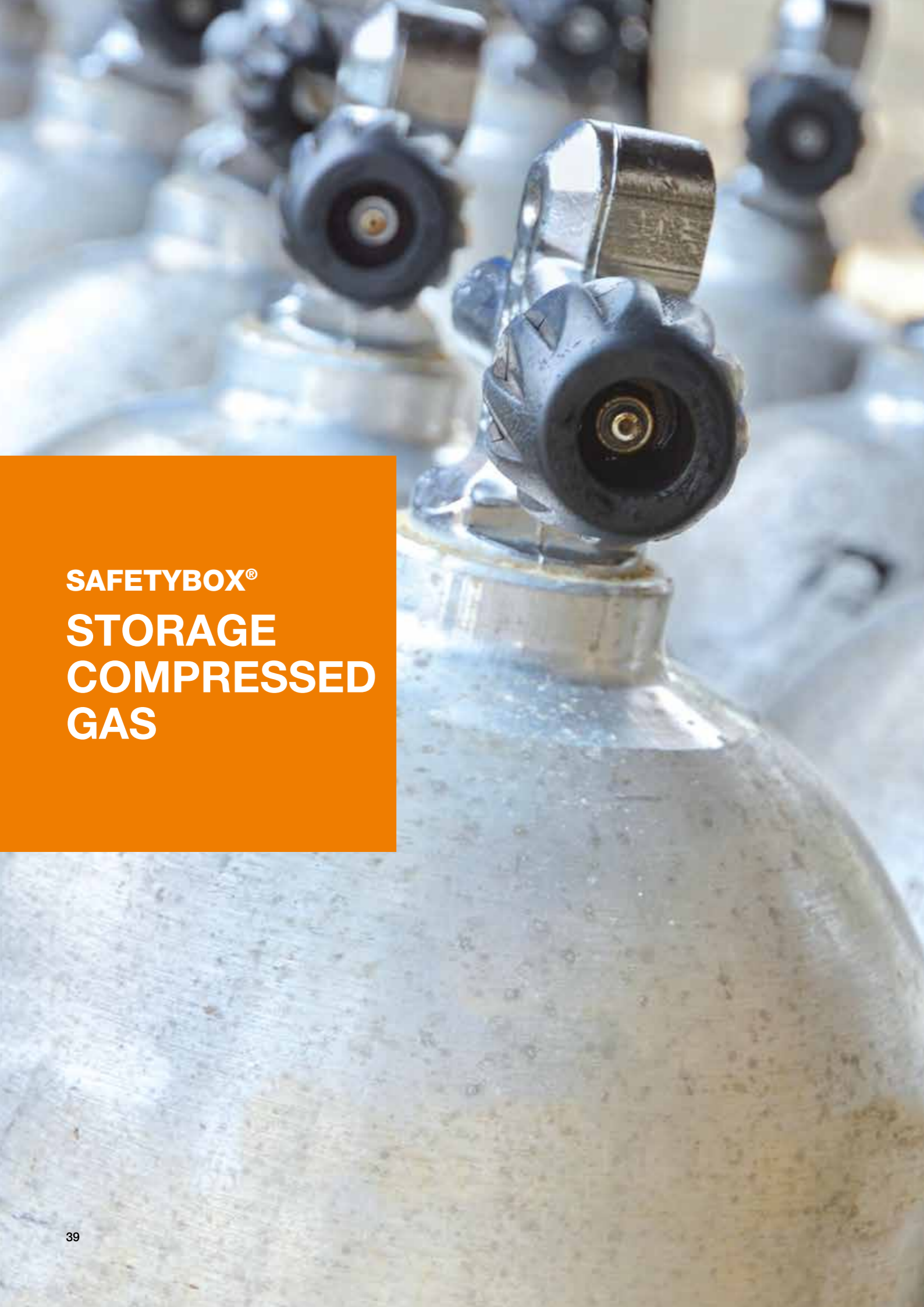

**SAFETYBOX®
STORAGE
COMPRESSED
GAS**

Safety cabinets for the storage of compressed gas cylinders in compliance with **EN 14470-2, EN 14727.**
Outdoor compressed gas cylinder storage, SINAL tested.

INDEX

INDOOR COMPRESSED GAS CYLINDER STORAGE41
OUTDOOR COMPRESSED GAS CYLINDER STORAGE ...43
ACCESSORIES45

BC 1350 GS
BC 650 S

Indoor safety cabinet for the storage of compressed gas cylinders, TÜV certified.



BC 1350 GS



BC 650 S



- Completely produced in pickled steel, 10/10 mm thickness, painted with epoxide acid-proof dusts and passage through thermic tunnel at 200°C. Thickness of painting from a minimum of 60µm (micron) to a maximum of 250µm (micron) as per UNI EN ISO 9001 procedure.
- **External monolithic construction, internal body resistant to corrosive products.**
- Fire-proof insulation made of highly fire resistant material, completely ecological.
- **Double, inflatable and anti-dust trimmings, and with protection against "cold and hot fumes".**
- Hinged closing door.
- Two mechanical certified safety valves with automatic closure at 70 ± 10°C. (Ø 100 mm).
- **Predisposed for piping gas installations.**
- **Space available for gas adaptor fittings and main gas flow command panel.**
- Brackets for gas cylinders' holding.
- Metal ramp to enable an easy placement of the cylinders in the cabinet.
- Security lock with key and extractable cylinder.
- "Fire" and "No smoking" warning stickers as per European Norms (DIN 4844 and ISO 3864).
- Grounding connection to discharge build-up of static electricity.
- 4 Levelling feet for balance.
- **"Product and public liability insurance" valid for all lifelong of the cabinet.**
- Usage and maintenance manual.
- **Packaging with "Tipping over system®" device.**

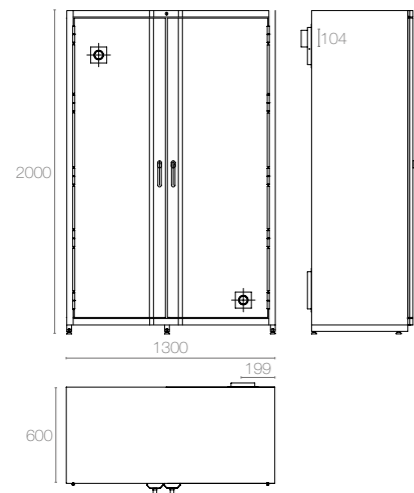

BC 1350 GS
 -External dimensions (LxDxH): 1300x600x2000 mm
 -Internal dimensions (LxDxH): 1165x500x1845 mm
 -Weight: 460 Kg
 -Storage capacity: ~1088 lt

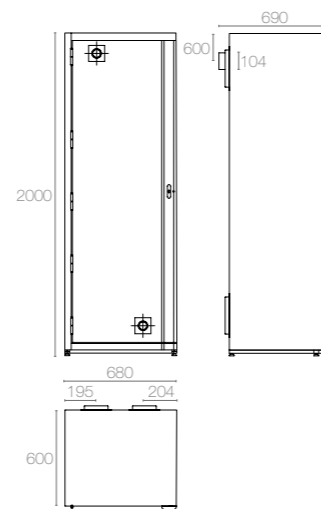

BC 650 S
 -External dimensions (LxDxH): 700x600x2015 mm
 -Internal dimensions (LxDxH): 445/403x548x1787 mm
 -Weight: 212 Kg
 -Storage capacity: ~435 lt

DEPOSITO BOMBOLE

Modular unit for outdoor storage of compressed gas cylinders.



SD3

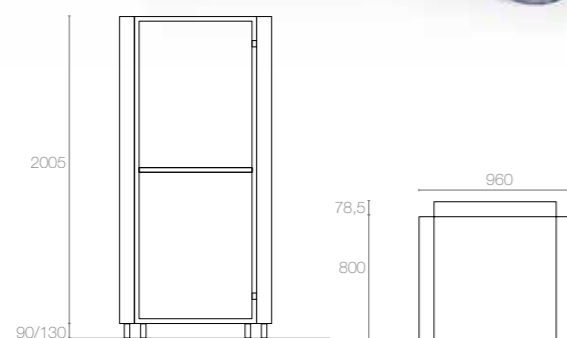







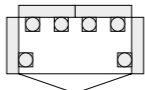
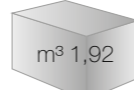
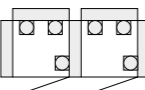

SD3
 -External dimensions (LxDxH): 960x880x2400 mm
 -Weight: 262 Kg

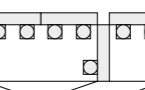
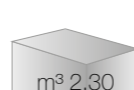
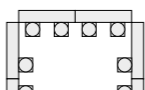
- Folded and welded steel panels onto girders to avoid structural deflection.
 Supplied with adjustable legs for fixing onto concrete base.
 Panel cavities may be filled with sand or concrete once fixed to the base.
- Produced with electrogalvanized steel and outlines, painted with epoxide and polyester acid-proof dusts electrostatically applied through thermic tunnel at 200°C.
- Modular design (see below).
- Fitted with continuous earthing system for each unit.
- Modular roof construction made of tarred corrugated board, fixed onto a varnished steel load bearing support.
- P.V.C. rain gutter.
- Front doors with anti-intrusion mesh, supplied with safety lock.
- Possibility to store fuel and oxidizing separately.
- "Product and public liability insurance" valid for all lifelong of the cabinet.

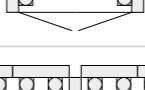
OTHER AVAILABLE MODELS

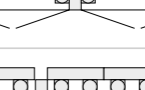
MODULAR BOX DISASSEMBLED SUPPLIED

PACKING AND WEIGHT	DIMENSIONS	CODE AND DESCRIPTION
 1 Pallet m ³ 1,92 Gross weight 395 Net weight 377		Deposito Bombole SD6 Dimensions: (LxDxH) 1760x880x2400mm
 1 Pallet m ³ 1,92 Gross weight 466 Net weight 448		Deposito Bombole SD3+3 Dimensions: (LxDxH) 1840x880x2400mm
 1 Pallet m ³ 2,30 Gross weight 586 Net weight 568		Deposito Bombole SD6+3 Dimensions: (LxDxH) 2640x880x2400mm
 1 Pallet m ³ 2,30 Gross weight 568 Net weight 550		Deposito Bombole SD10 Dimensions: (LxDxH) 1760x1680x2400mm
 1 Pallet m ³ 2,88 Gross weight 781 Net weight 683		Deposito Bombole S6+6 Dimensions: (LxDxH) 3440x880x2400mm
 1 Pallet m ³ 1,92x2 Gross weight 911 Net weight 875		Deposito Bombole S6+6+3 Dimensions: (LxDxH) 4320x880x2400mm
 1 Pallet m ³ 1,92x2 Gross weight 945 Net weight 909		Deposito Bombole S10+10 Dimensions: (LxDxH) 3440x1680x2400mm

Accessories



CONTAINER
for small gas cylinders
(LxDxH) 440x200x420 mm.



INTERNAL FILTRATION SYSTEM
with activated charcoal filter
and **Cunctator®**.



UNICUM ASPIRATOR AND FILTER
in a single box
(possibility to supply it
with thermostat).



ANTI-SPARK OR ATEX ASPIRATORS
220V/230V.



EXHAUST FUMES CONVEYOR



CARBOX[®]
FILTRATION
SYSTEMS

Filtration systems for the treatment of harmful fumes resulting from chemical processings.

INDEX

PHARMACEUTICAL HOODS	49
ACTIVATED CHARCOAL FILTERS	53

CAP-FARM 60

Aspirated and filtered hood for pharmaceutical use with Hepa filter H 14 or activated charcoal filter.

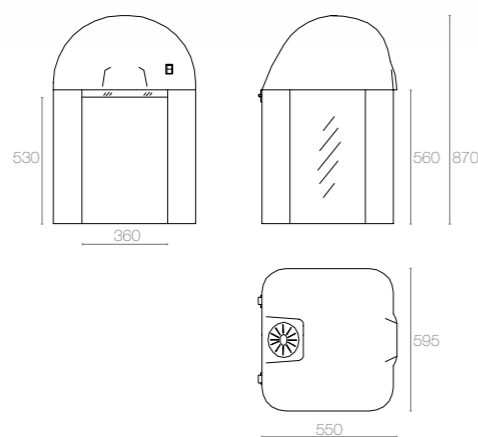

CAP-FARM 60

**CAP-FARM 60**

- External dimensions (LxDxH): 600x550x870 mm
- Frontal-access dimensions: 360x530 mm
- Weight: 24 Kg

- The dome is built with extruded ABS.
- Side protection are made of transparent Plexiglass and profiles are in yellow extruded aluminium as the dome.
- Internal aspiration and filtration system.
- It is apt to avoid particles contamination during the preparation of compounds liable to produce dusts.
- Filter: Hepa filter H 14 or activated charcoal filter.
- Input voltage: Volt 220/230.
- Frequency 50/60 Hz
- Max absorbed power: 34/49W.
- ON/OFF lamp.



ACTIVATED CHARCOAL FILTER



HEPA FILTER

CAP-FARM 60/B

Aspirated and filtered hood for pharmaceutical use with Hepa filter H 14 or activated charcoal filter.



CAP-FARM 60/B

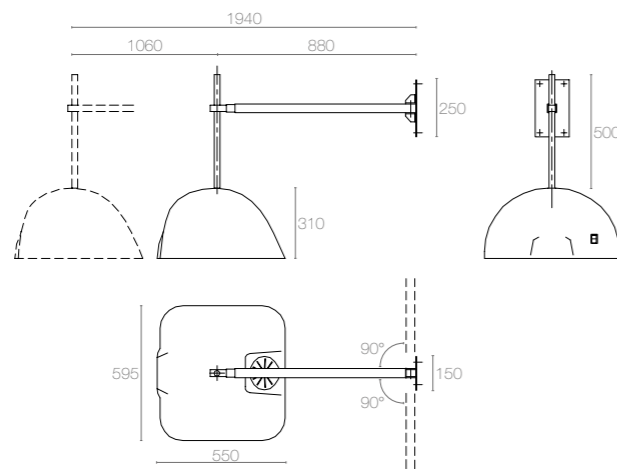

CAP-FARM 60/B
 -External dimensions (LxDxH): 600x560x860 mm
 -Frontal-access dimensions: 370x520 mm
 -Weight: 19,5 Kg

- The dome is built with extruded ABS.
- Equipped with mobile arm fixed to the wall for moving the hood in different directions.
The arm must be fixed to the supporting- wall.
- Filter: Hepa filter H 14 or activated charcoal filter.
- Input voltage: Volt 220/230.
- Frequency 50/60 Hz
- Max absorbed power: 34/49W.
- ON/OFF lamp.
- Minimum arm-extension: cm 90.
- Maximum arm extension: cm 190.
- Arm rotation: 180°, covering the entire wall.
- Rotation hood on itself on cylindrical support.
- Maximum stroke high-low: cm 45.



ACTIVATED CHARCOAL FILTER



HEPA FILTER

FILTER BM FILTER BP

Activated charcoal filter in grains.

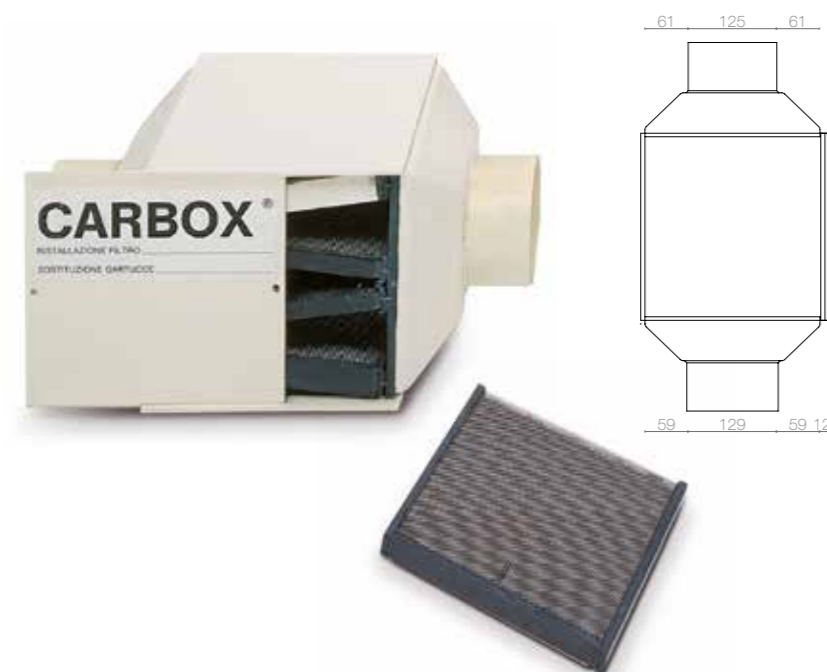

FILTER BM

- Building material PVC/STAINLESS STEEL.
- No.4 filtrating cells, weight 5 kg.
- Ø in-out 125 mm.

ACCESSORIES

- Spare filter BM (code SET002).

•External dimensions (LxPxH): 265x520x255 mm
•Dimensions of spare filter (LxPxH): 245x235x40 mm
•Weight: 9 Kg

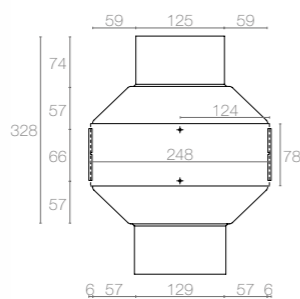

FILTER BP

- Building material PVC/STAINLESS STEEL.
- No.1 filtrating cell, weight 1,75 kg.
- Ø in-out 125 mm.

ACCESSORIES

- Spare filter BP (code SET001).

•External dimensions (LxPxH): 260x270x320 mm
•Dimensions of spare filter (LxPxH): 245x235x40 mm
•Weight: 3,5 Kg

FILTER B4 FILTER B6

Activated charcoal filter in grains.

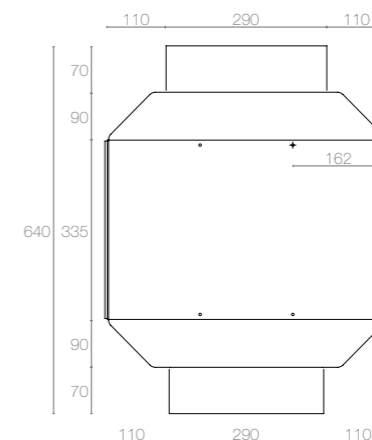

FILTER B4

- Building material PVC/STAINLESS STEEL.
- No.4 filtrating cells, weight 13 kg.
- Ø in-out 250 mm.

ACCESSORIES

- Predisposed for pre-filter.
- Filter B4 special: possibility to use selective charcoal mixture to absorb special substances, on demand.
- Spare filter B4 (code SET003).

•External dimensions (LxPxH): 500x490x640 mm
•Dimensions of spare filter (LxPxH): 470x265x40 mm
•Weight: 27 Kg

FILTER B6

- Building material PVC/STAINLESS STEEL.
- No.6 filtrating cells, weight 19 kg.
- Ø in-out 250 mm.

ACCESSORIES

- Predisposed for pre-filter.
- Filter B6 special: possibility to use selective charcoal mixture to absorb special substances, on demand.
- Spare filter B6 (code SET004).

•External dimensions (LxPxH): 650x490x690 mm
•Dimensions of spare filter (LxPxH): 470x265x40 mm
•Weight: 27 Kg

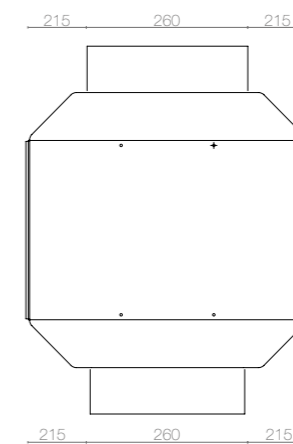

FILTER BE4 FILTER BE6

Activated charcoal filter in grains.

CARBOX-VENT BE4/1300 CARBOX-VENT BE6/1300

Aspirated charcoal filters.

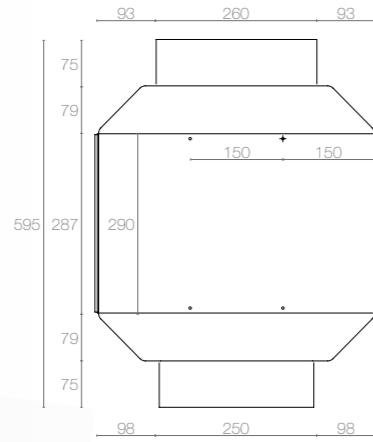

FILTER BE4

- Building material PVC/Polypropylene
- No.4 filtrating cells, weight 10 kg.
- Ø in-out 250 mm.

ACCESSORIES

- Predisposed for pre-filter.
- Spare filter BE4 (code SET003E).

•External dimensions (LxPxH): 590x460x460 mm
•Dimensions of spare filter (LxPxH): 435x215x30 mm
•Weight: 24 Kg

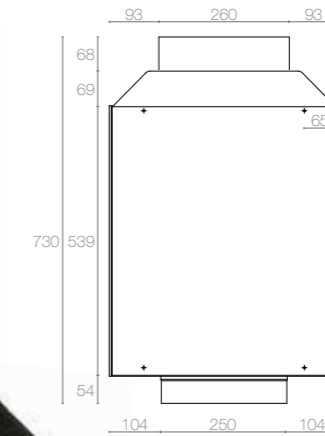

CARBOX-VENT BE4/1300

- Building material PVC/STAINLESS STEEL/PP.
- No.4 filtrating cells.
- Ø in-out 250 mm.
- Aspirator power mc/h 1300.
- Max absorbed power: 170 W.

•External dimensions (LxPxH): 455x730x455 mm
•Weight: 30 Kg

FILTER BE6

- Building material PVC/Polypropylene
- No.6 filtrating cells, weight 16 kg.
- Ø in-out 250 mm.

ACCESSORIES

- Predisposed for pre-filter.
- Spare filter BE6 (cod.art.SET004E).

•External dimensions (LxPxH): 590x460x460 mm
•Dimensions of spare filter (LxPxH): 235x215x30 mm
•Weight: 30 Kg

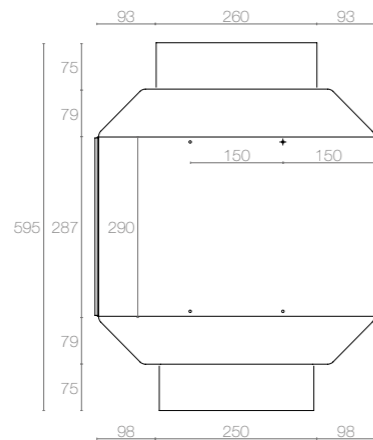

CARBOX-VENT BE6/1300

- Building material PVC/STAINLESS STEEL/PP.
- No.6 filtrating cells.
- Ø in-out 250 mm.
- Aspirator power mc/h 1300.
- Max absorbed power: 170 W.

•External dimensions (LxPxH):455x730x455 mm
•Weight: 33 Kg

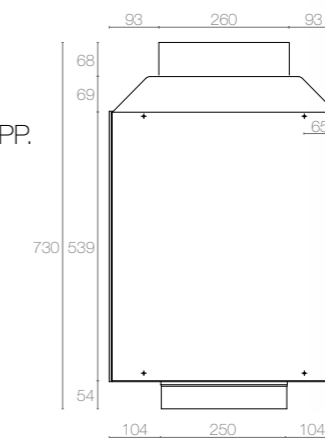

INFORMATION SHEET



ADSORPTIVE CAPACITY FOR VAPOR CONTAMINANTS

In general, vapor contaminants can be categorized in terms of how well they are adsorbed by activated carbon. Adsorptive capacity is a function of the carbon's affinity for a specific type of contaminant, such as ketones, aliphatics, aromatics, and sulfur compounds. Additionally, the adsorptive capacity and removal efficiency may be affected by:

- The concentration of the contaminant(s)
- Humidity of the air or gas stream
- Temperature of the vapor laden air stream
- Carbon bed contact time with vapor laden air
- Superficial velocity through the carbon filter
- Particle size of activated carbon
- Grade of activated carbon used

To assist in estimating the activated carbon's ability to remove certain compounds, a reference chart and index of commonly encountered contaminants are presented below.

Category	Rating	Adsorptive Capacity, % wt.	Average Adsorptive Capacity, %
1	High	20 to 50%	35
2	Good	10 to 20%	16
3	Moderate	Less than 15%	8
4	Low	Usually too low to be effective*	

*Impregnated carbon may be required if applicable

In addition to the specific compounds mentioned below some types of odors, which are hard to categorize, are also effectively removed with activated carbon.

CATEGORY 1			
Acetic anhydride	Caprylic acid	Dichlorodifluoromethane	Ethylene dichloride
Acrylic acid	Carbolic acid	Dichloroethane	thyl silicate
Acrylonitrile	Carbon disulfide	Dichloroethylene	Freon 11, 12, 114
Adhesives	Carbon tetrachloride	Dichloroethyl ether	Gasoline
Allyl chloride	Cellosolve acetate	Dichloronitroethane	Heptane
Amyl acetate	Chlorobenzene	Dichloropropane	Heptylene
Amyl alcohol	Chlorobutadiene	Dichlorotetrafluoroethane	Iodine
Amyl ether	Chloroform	Dicyclopentadiene	Iodoform
Aniline	Chloronitropropane	Diesel fumes	Isopropyl acetate
Antiseptics	Chloropicrin	Diethyl ketone	Isopropyl alcohol
Asphalt fumes	Cigarette smoke	Dimethylaniline	Isopropyl chloride
Benzene	Creosote	Dimethyl sulfate	Isopropyl ether
Bromine	Cresol	Dioxane	Kerosene
Butanone	Cyclohexane	Dipropyl ketone	Krypton delay
Butyl acetate	Cyclohexanol	Epichlorhydrin	Lactic acid
Butyl alcohol	Cyclohexanone	Ethyl acetate	Liquid fuel
Butyl cellosolve	Cyclohexene	Ethyl acrylate	Lubricating oils and greases
Butyl chloride	Decane	Ethyl benzene	Lysol
Butyl ether	Dibromoethane	Ethyl bromide	Menthol
Butyric acid Camphor	Dichlorobenzene	Ethylene chlorhydrin	Mercaptans (large chain)

Mesityl oxide	Nicotine	Propionic acid	Trichloroethylene
Methyl acrylate	Nitrobenzene	Propyl acetate	Trichlorofluoromethane
Methyl butyl ketone	Nitroethane	Propyl alcohol	Turpentine
Methyl cellosolve	Nitroglycerine	Propyl chloride	Urea
Methyl chloroform	Nitropropane	Propyl ether	Uric acid
Methyl cyclohexane	Nitrotoluene	Propyl mercaptan	Valeric acid
Methyl cyclohexanol	Nonane	Styrene monomer	Valeric aldehyde
Methyl cyclohexanone	Octane	Tar	Varnish fumes
Methylene chloride	Octene	Tetrachloroethane	Vinegar
Methyl ethyl ketone	Ozone	Tetrachloroethylene	Vinyl acetate
Methyl glycol	Palmitic acid	Tetrahydrofuran	Vinyl chloride monomer
Methyl isobutyl ketone	Para-dichlorobenzene	Thiophene	Xenon delay
Methyl methacrylate ester	Pentanone	Toluene	Xylene
Monochlorobenzene Naphtha	Perchloroethylene	Toluene - 2,4,- diisocyanate	
Naphthalene	Phenol	Trichloroethane	

CATEGORY 2			
Acetic acid	Dimethyl sulfide	Hexyne	Nitromethane
Acetone	Ether	*Hydrogen iodide	Pentane
Acrolein	Ethyl alcohol	*Hydrogen sulfide	Pentylene
Butadiene	Ethyl chloride	Methyl acetate	Pentyne
Butyraldehyde	Ethyl formate	Methyl bromide	Phosgene
Chlorine	*Ethyl mercaptan	Methyl chloride	Propionaldehyde
Combustion odors	Hexane	Methyl ether	Rubber fumes
Dichloromonofluoro- methane (Freon 21)	Hexene	Methyl formate	*Sewage odors

CATEGORY 3			
Acetaldehyde	Carbon dioxide	*Hydrogen fluoride	Propane
Acetonitrile	Ethylene oxide	*Hydrogen selenide	*Sulfur dioxide
Acetylene	*Formaldehyde	Methyl alcohol	*Sulfuric acid
*Amines	*Formic acid	*Methyl mercaptan	*Sulfurtrioxide
Butane	*Hydrogen bromide	*Nitric acid	
Butylene	*Hydrogen chloride	*Nitrogen dioxide	

CATEGORY 4			
*Ammonia	Ethane	Hydrogen	*Mercury vapors
Carbon monoxide	Ethylene	*Hydrogen cyanide	Methane

*Materials marked with an asterisk may require an impregnated carbon to achieve desired removal efficiencies.



UTILITIES

Cabinets and accessories for the protection of the user and environment .

INDEX

- SICUR WOOD..... 61
- SICUR..... 63
- SICUR KEM..... 64
- SICUR SHELF..... 65
- PHYTOSAFETY®..... 66
- DRUM STORAGE SUMPS..... 67
- ABSORBENT PADS..... 68
- EMERGENCY EYE AND BODY SHOWER..... 69

SICUR WOOD 120 SICUR WOOD 60

Melamine cabinet for the storage of chemical products.
Predisposed for connection to a central aspiration system



SICUR WOOD 120



SICUR WOOD 60

- Entirely produced in melamine fire-proof wood.
- Joint assembled body by pins and ABS edging.
- Protective metal sheet base.
- **Palletized base** for easier transportation of the cabinet.
- Vertical partition (just for SICURWOOD 120).
- **5 drawers on sliding guides**. Loading capacity of the guides 30 kg.
- Doors opening up to 95°.
- Internal hinges with closing spring.
- Handle and security lock with key and extractable cylinder.
- "Danger" warning stickers.
- Levelling feet for balance.
- **"Product and public liability insurance" valid for all lifelong of the cabinet.**
- Usage and maintenance manual.
- **Packaging with "Tipping over system®" device.**

ACCESSORIES

Aspirator and filter for cabinets.



KIT01



SICUR WOOD 120

- 2 doors
- **External dimensions (LxDxH):** 1200x520x1990 mm
- **Weight:** 187 Kg

SICUR WOOD 60

- 1 door
- **External dimensions (LxDxH):** 600x520x1990 mm
- **Weight:** 106 Kg

SICUR 100
SICUR 60

Cabinet for the storage of flammable liquids.



SICUR 100
-2 doors
-External dimensions (LxDxH): 1075x500x1850 mm
-Weight: 88 Kg



SICUR 60
-1 door
-External dimensions (LxDxH): 575x500x1850 mm
-Weight: 57 Kg

- Completely produced in pickled steel, 10/10 thickness, painted with dusts.
- Rounded off edges and invisible screws.
- **Aeration grids for natural ventilation**, not forced.
- Closure with bar, plastic and metal lock with ergonomic handle; supplied with double key.
- Reinforced steel hinges 15/10.
- 3 tray- shaped shelves adjustable in height and bottom basin.
- Grounding connection to discharge build-up of static electricity.
- Levelling feet for balance.
- **The cabinet is disassembled and supplied with an easy assembly kit.**
- "Danger" warning stickers.
- "Product and public liability insurance" valid for all lifelong of the cabinet.

OTHER AVAILABLE MODELS

SICUR 100 SMALL: height 1100 mm
SICUR 60 SMALL: height 1100 mm

SICUR KEM 100
SICUR KEM 50

Safety metal cabinet for the storage of mildly aggressive chemical and toxic products.



SICUR KEM 100
-2 doors
-External dimensions (LxDxH): 1000x470x2000 mm
-Weight: 80 Kg



SICUR KEM 50
-1 door
-External dimensions (LxDxH): 530x470x2000 mm
-Weight: 45 Kg

- Completely produced in bended sheet layer thickness 0,8 mm with upper reinforcement of 1,5 mm and lower reinforcement of 1,2 mm.
- Painted at 190°C with no heavy metals powders.
- Internal sheet metal shelves adjustable in height.
- Metal doors with lock and bars.
- **Aeration grids for natural ventilation** with upper hole (Ø 125mm) for connection to a filtration-aspiration system.
- Palletized base for easier transportation of the cabinet.
- **The cabinet is disassembled and supplied with an easy assembly kit.**
- "Product and public liability insurance" valid for all lifelong of the cabinet.

ACCESSORIES

- KIT 01 - aspirator and filter for storage of chemicals and harmful products.

SICUR SHELF

Shelving for chemical, acid and base products.



SICUR SHELF
 • External dimensions (LxDxH): 1200x500x2000 mm
 • Shelf dimensions (LxD): 1200x500 mm
 • Basin dimensions (LxDxH): 1200x500x20 mm

- **Anti-acid painted steel frame** with squared pipes 30x30mm.
- Supplied with **5 shelves** with steel hooks.
- **5 polypropylene basins** to contain any eventual spills, to be fitted on the shelves.
- Shelf loading 180 kg.

ACCESSORIES

- "Bridge" device for stabilization.
- Fixing brackets.
- Holder support.
- Fixing element to the ceiling.
- Cross device for stabilization.

PHYTOSAFETY® 100

Safety cabinet for the storage of phytopharmaceuticals, pesticides and phytosanitararies.



PHYTOSAFETY® 100
 • External dimensions (LxDxH): 1000x470x2000 mm
 • Weight: 76 Kg

- Completely produced in bended sheet layer thickness 0,8 mm with upper reinforcement of 1,5 mm and lower reinforcement of 1,2 mm.
- Painted at 190°C with no heavy metals powders.
- **4 tray-shaped shelves**, adjustable in height and bottom basin.
- Doors opening up to 110°.
- Doors with lock and bars, and front aeration grid for natural ventilation.
- Upper hole for connection to a filtration-aspiration system.
- **The cabinet is disassembled and supplied with an easy assembly kit.**
- **"Product and public liability insurance" valid for all lifelong of the cabinet.**

ACCESSORIES AND OTHER AVAILABLE MODELS

- KIT 01 - aspirator and filter for storage of chemicals and harmful products.
- Possibility to supply the cabinet with CLOTHES-RAIL.

DRUM STORAGE SUMPS



- Watertight covered sump, **containment volume according to law.**
- **Sheet thickness 15/10**, this allows the sump to be more solid and eventually prevent any impact.
- Painted basins: the painting creates a protective coat against atmospheric agents and eventual impacts.
- The sump, besides the restraining edge, has a reinforced frame that, during the handling of drums, gives stability to the whole structure.
- **Possibility to store up to 4 drums of 200 lt.**
- **Possibility to supply the sump with an internal shelf to horizontally store drums of 60 lt**, as well as the storage of small containers. Suitable for flammable products.
- **Side wall with lamellate air intake** to grant the necessary air recycle. Suitable for outdoor installation.
- Possibility to close the sump with padlock to protect the contents from non-authorized personnel.
- Security labelling.

ABSORBENT PADS



- Absorbent pads 100% made of polypropylene.
- Vivid pink color for ease of viewing, with stitching to rapidly permeate liquids.
- Treated to absorb high concentration of corrosive liquids: for instance sulfuric acid and sodium hydroxide.

LOM 100
LOP 100



LOM 100

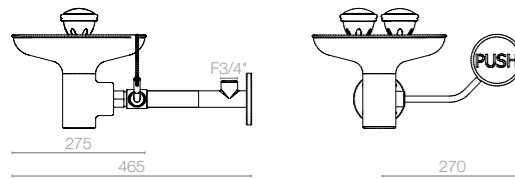

- **Application:**
Wall mounting.
- **Details:**
Test pressure: 9 bar/air.
Max working pressure: 10 bar.
Flow rate limited to 16 L/min.
- **Surface protection:**
Epoxy painted.
- **Materials:**
Brass.
ABS.
Stainless steel.
- **Headwork sealing:**
PTFE temperature working range: 0-70°C.
- **Connection:** G3/4" female.
- **Standard and norms:**
DIN 4844-2-D.
BGV A8.
DIN EN 15154-2:2006.
ANSA Z358.1-2004.

OTHER AVAILABLE MODELS

- Completely in stainless steel.

LOP 101
LOP 102

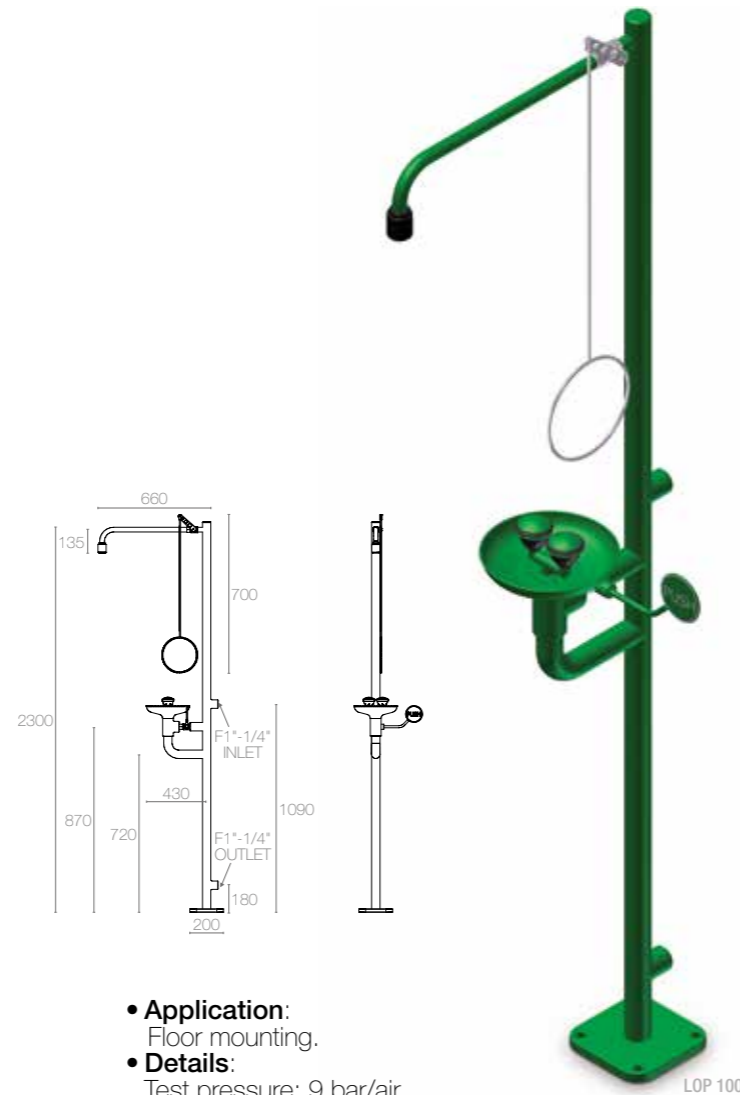

LOP 100

- **Application:**
Floor mounting.
- **Details:**
Test pressure: 9 bar/air.
Max working pressure: 10 bar.
Flow rate limited to 50 L/min.
- **Surface protection:**
Epoxy painted/nichel plating.
- **Materials:**
Brass.
ABS.
Stainless steel.
- **Headwork sealing:**
PTFE temperature working range: 0-70°C.
- **Connection:** G1"-1/4" female.
- **Standard and norms:**
DIN 4844-2-D e
BGV A8.
DIN EN 15154-1:2006.
DIN EN 15154-2:2006.
DIN 12899-3:2009.
DIN 67510.
ANSI Z358.1-2004.

OTHER AVAILABLE MODELS

- Completely in stainless steel.

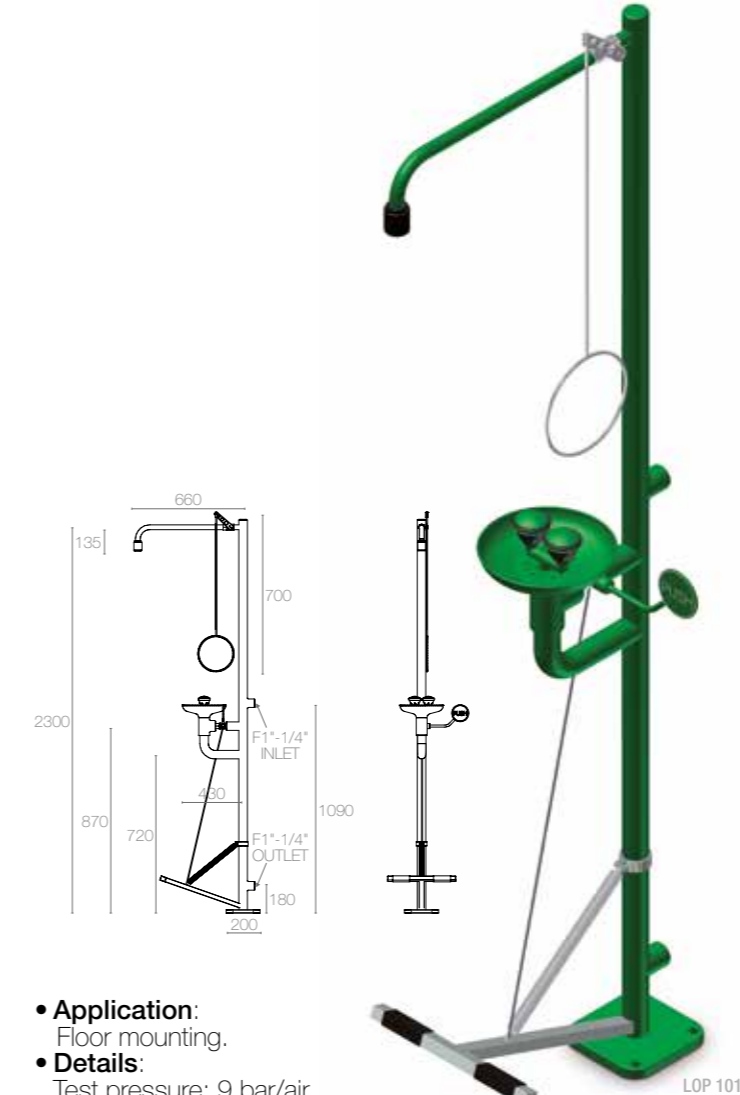

LOP 101

- **Application:**
Floor mounting.
- **Details:**
Test pressure: 9 bar/air.
Max working pressure: 10 bar.
Flow rate limited to 50 L/min.
- **Surface protection:**
Epoxy painted/nichel plating.
- **Materials:**
Brass.
ABS.
Stainless steel.
- **Headwork sealing:**
PTFE temperature working range: 0-70°C.
- **Connection:** G1"-1/4" female.
- **Standard and norms:**
DIN 4844-2-D e
BGV A8.
DIN EN 15154-1:2006.
DIN EN 15154-2:2006.
DIN 12899-3:2009.
DIN 67510.
ANSI Z358.1-2004.

OTHER AVAILABLE MODELS

- Completely in stainless steel.



LOP 102

- **Application:**
Floor mounting.
- **Details:**
Test pressure: 9 bar/air.
Max working pressure: 10 bar.
Flow rate limited to 16 L/min.
- **Surface protection:**
Epoxy painted/nichel plating.
- **Materials:**
Brass.
ABS.
Stainless steel.
- **Headwork sealing:**
PTFE temperature working range: 0-70°C.
- **Connection:** G1"-1/4" female.
- **Standard and norms:**
DIN 4844-2-D e
BGV A8.
DIN EN 15154-2:2006.
ANSI Z358.1-2004.

OTHER AVAILABLE MODELS

- Completely in stainless steel.

ur safety ensuring your safety ensuring you
g your safety ensuring your safety ensuring
nsuring your safety ensuring your safety en
ing your safety ensuring your safety ensuri
your safety ensuring your safety ensuring
ring your safety ensuring your safety ensuri
ensuring your safety ensuring your safety
safety ensuring your safety ensuring your
ur safety ensuring your safety ensuring you
g your safety ensuring your safety ensuring
nsuring your safety ensuring your safety en
safety ensuring your safety ensuring your saf
your safety ensuring your safety ensuring
ring your safety ensuring your safety ensuri
ensuring your safety ensuring your safety
safety ensuring your safety ensuring your
ur safety ensuring your safety ensuring you
g your safety ensuring your safety ensuring
nsuring your safety ensuring your safety en
safety ensuring your safety ensuring your saf
your safety ensuri r safety ensuring
ring your safe r safety ensuri
ensuring your safy wing your safety
safety ensuring your safety ensuring your



Via E. Majorana, 12
31025 Santa Lucia di Piave - TV - Italy
Tel. +39 0438 451054 - Fax +39 0438 455784
info@safetybox.it - www.safetybox.it

